

# Aluminum Wires

## MaxalMig ER1100

### Benefits:

- highest ductility/formability
- higher electrical and thermal conductivity
- excellent corrosion resistance
- good hot cracking sensitivity in most applications

### Typical Applications:

- electrical conductors
- chemical storage tanks
- piping and tubing for chemicals
- refrigeration

### Typical Weld Metal Chemistry:

Silicon+Iron shall not exceed...	0.95
Copper	0.05-0.20
Manganese	0.05
Magnesium	—
Zinc	0.10
Titanium	—
Beryllium	< 0.0003
Others Total	0.15
Aluminum	99.0

### Typical Mechanical Properties (AW):

Tensile Strength (psi)	13,500 (90 MPa)
Yield Strength (psi)	—
Elongation % in 2" (50mm)	40%

### Suggested GMAW welding procedures:

Diameter	Base Material		Wire Feed		
	Thickness	Amps	Volts	Speed (ipm)	
0.030"/0.8 mm	1/16" (1.6mm)	90	20	260	
	3/32" (2.4mm)	110	22	350	
	1/8" (3.2mm)	130	23	450	
	3/16" (4.8mm)	150	24	550	
0.035"/0.9mm	1/4" (6.4mm)	175	24	650	
	1/8" (3.2mm)	130	24	400	
	1/4" (6.4mm)	170	25	500	
0.047"/1.2mm	3/32" (2.4mm)	110	25	170	
	1/8" (3.2mm)	150	26	270	
	1/4" (6.4mm)	190	26	320	
	3/8" (9.5mm)	220	27	390	
0.062"/1.6mm	1/4" (6.4mm)	200	26	170	
	3/8" (9.5mm)	230	27	200	
	1/2" (12.7mm)	260	28	240	
	3/4" (19.1mm)	280	29	260	
	1.00" (25.4mm)	300	30	280	

**Shielding Gas:** 100% Ar, 75% He/25% Ar

**Type of Current:** DCEP

### Approvals and Conformances:

- AWS A5.10, ER1100
- ASME SFA 5.10, ER1100
- AWS A5.01, Class S1, Schedule F
- CWB
- CE

## MaxalMig ER4043

### Benefits:

- moderate strength (28ksi/190Mpa typical)
- low melting temperature and high fluidity
- minimizes hot cracking and distortion
- clean, bright welds

### Typical Applications:

- sport products - scooters/bicycles
- general repair and maintenance
- automotive/motorcycle frames and wheels
- welding 6XXX alloys

### Typical Weld Metal Chemistry:

Silicon	4.5-6.0
Iron	0.80
Copper	0.30
Manganese	0.05
Magnesium	0.05
Chromium	—
Zinc	0.10
Titanium	0.20
Beryllium	< 0.0003
Others Total	0.15
Aluminum	remainder

### Typical Mechanical Properties (AW):

Tensile Strength (psi)	28,000 (190 MPa)
Yield Strength (psi)	12,000 (80 MPa)
Elongation % in 2" (50mm)	24%

### Suggested GMAW welding procedures:

Diameter	Base Material		Wire Feed		
	Thickness	Amps	Volts	Speed (ipm)	
0.030"/0.8 mm	1/16" (1.6mm)	90	20	260	
	3/32" (2.4mm)	110	22	350	
	1/8" (3.2mm)	130	23	450	
	3/16" (4.8mm)	150	24	550	
0.035"/0.9mm	1/4" (6.4mm)	175	24	650	
	1/8" (3.2mm)	130	24	400	
	1/4" (6.4mm)	170	25	500	
0.047"/1.2mm	3/32" (2.4mm)	110	25	170	
	1/8" (3.2mm)	150	26	270	
	1/4" (6.4mm)	190	26	320	
	3/8" (9.5mm)	220	27	390	
0.062"/1.6mm	1/4" (6.4mm)	200	26	170	
	3/8" (9.5mm)	230	27	200	
	1/2" (12.7mm)	260	28	240	
	3/4" (19.1mm)	280	29	260	
	1.00" (25.4mm)	300	30	280	

**Shielding Gas:** 100% Ar, 75% He/25% Ar

**Type of Current:** DCEP

### Approvals and Conformances:

- AWS A5.10, ER4043
- ASME SFA 5.10, ER4043
- AWS A5.01, Class S1, Schedule F
- CWB
- CE

## MaxalMig ER4047

### Benefits:

- low melting temperature and high fluidity
- excellent wetting action for joint sealing applications
- lowest shrinkage rate/reduced distortion
- minimizes hot cracking

### Typical Applications:

- welding 6XXX alloys
- radiator and air conditioning components
- general repair and maintenance
- water and gas tight applications

### Typical Weld Metal Chemistry:

Silicon	11.0-13.0
Iron	0.80
Copper	0.30
Manganese	0.15
Magnesium	—
Chromium	—
Zinc	0.10
Titanium	—
Beryllium	< 0.0003
Others Total	0.15
Aluminum	remainder

### Typical Mechanical Properties (AW):

Tensile Strength (psi)	38,000 (260 MPa)
Yield Strength (psi)	20,000 (135 MPa)
Elongation % in 2" (50mm)	11%

### Suggested GMAW welding procedures:

Diameter	Base Material		Wire Feed		
	Thickness	Amps	Volts	Speed (ipm)	
0.030"/0.8 mm	1/16" (1.6mm)	90	20	260	
	3/32" (2.4mm)	110	22	350	
	1/8" (3.2mm)	130	23	450	
	3/16" (4.8mm)	150	24	550	
0.035"/0.9mm	1/4" (6.4mm)	175	24	650	
	1/8" (3.2mm)	130	24	400	
	1/4" (6.4mm)	170	25	500	
0.047"/1.2mm	3/32" (2.4mm)	110	25	170	
	1/8" (3.2mm)	150	26	270	
	1/4" (6.4mm)	190	26	320	
	3/8" (9.5mm)	220	27	390	
0.062"/1.6mm	1/4" (6.4mm)	200	26	170	
	3/8" (9.5mm)	230	27	200	
	1/2" (12.7mm)	260	28	240	
	3/4" (19.1mm)	280	29	260	
	1.00" (25.4mm)	300	30	280	

**Shielding Gas:** 100% Ar, 75% He/25% Ar

**Type of Current:** DCEP

### Approvals and Conformances:

- AWS A5.10, ER4047
- ASME SFA 5.10, ER4047
- AWS A5.01, Class S1, Schedule F
- CE

## MaxalMig ER4943

### Benefits:

- 25% higher UTS and 50% higher yield strength than 4043 in as-welded condition
- moderate to high strength (35ksi/240mpa typical)
- low melting temperature and high fluidity
- heat treatable

### Typical Applications:

- current 4043 and 4643 applications, 1XXX, 3XXX, 5XXX with less than 3.0% Mg (example 5052), and 6XXX
- post weld aged, post weld heatreat & age applications
- automotive/motorcycle frames and wheels
- ladders and furniture

### Typical Weld Metal Chemistry:

Silicon .....	5.0-6.0
Iron .....	0.40
Copper .....	0.10
Manganese .....	0.05
Magnesium .....	0.30-0.50
Chromium .....	—
Zinc .....	0.10
Titanium .....	0.15
Beryllium .....	< 0.0003
Others Total .....	0.15
Aluminum.....	remainder

### Typical Mechanical Properties (AW):

Tensile Strength (psi)	35,000 (240 MPa)
Yield Strength (psi)	18,000 (125 MPa)
Elongation % in 2" (50mm)	16%

### Suggested GMAW welding procedures:

Diameter	Base Material		Wire Feed		
	Thickness	Amps	Volts	Speed	(ipm)
0.030"/0.8 mm	1/16" (1.6mm)	90	20	260	
	3/32" (2.4mm)	110	22	350	
	1/8" (3.2mm)	130	23	450	
	3/16"(4.8mm)	150	24	550	
0.035"/0.9mm	1/4" (6.4mm)	175	24	650	
	1/8" (3.2mm)	130	24	400	
	1/4" (6.4mm)	170	25	500	
0.047"/1.2mm	3/32" (2.4mm)	110	25	170	
	1/8" (3.2mm)	150	26	270	
	1/4" (6.4mm)	190	26	320	
	3/8" (9.5mm)	220	27	390	
0.062"/1.6mm	1/4" (6.4mm)	200	26	170	
	3/8" (9.5mm)	230	27	200	
	1/2" (12.7mm)	260	28	240	
	3/4" (19.1mm)	280	29	260	
1.00" (25.4mm)	300	30	280		

**Shielding Gas:** 100% Ar, 75% He/25% Ar

**Type of Current:** DCEP

### Approvals and Conformances:

- AWS A5.10, ER4943
- ASME SFA 5.10, ER4943
- AWS A5.01, Class S1, Schedule F
- CWB
- ABS
- CE

## MaxalMig ER5183

### Benefits:

- very high strength
- high ductility, fatigue strength and toughness
- very good color match after anodizing with 5XXX/6XXX base materials
- excellent corrosion resistance when welded to 5083 base metal

### Typical Applications:

- applications using base metal with 40ksi (275 Mpa) minimum (5083)
- shipbuilding
- pressure vessels
- cryogenic tanks

### Typical Weld Metal Chemistry:

Silicon .....	0.40
Iron .....	0.40
Copper .....	0.10
Manganese .....	0.50-1.0
Magnesium .....	4.3-5.2
Chromium .....	0.05-0.25
Zinc .....	0.25
Titanium .....	0.15
Beryllium .....	< 0.0003
Others Total .....	0.15
Aluminum.....	remainder

### Typical Mechanical Properties (AW):

Tensile Strength (psi)	41,000 (280 MPa)
Yield Strength (psi)	22,000 (150 MPa)
Elongation % in 2" (50mm)	12%

### Suggested GMAW welding procedures:

Diameter	Base Material		Wire Feed		
	Thickness	Amps	Volts	Speed	(ipm)
0.030"/0.8 mm	1/16" (1.6mm)	100	18	300	
	3/32" (2.4mm)	120	21	400	
	1/8" (3.2mm)	140	21	500	
	3/16"(4.8mm)	160	22	600	
0.035"/0.9mm	1/4" (6.4mm)	185	22	700	
	1/8" (3.2mm)	140	22	450	
	1/4" (6.4mm)	180	23	600	
0.047"/1.2mm	3/32" (2.4mm)	120	24	220	
	1/8" (3.2mm)	160	25	330	
	1/4" (6.4mm)	220	25	370	
	3/8" (9.5mm)	230	25	450	
0.062"/1.6mm	1/4" (6.4mm)	210	24	200	
	3/8" (9.5mm)	240	25	230	
	1/2" (12.7mm)	270	26	270	
	3/4" (19.1mm)	290	27	300	
1.00" (25.4mm)	310	28	320		

**Shielding Gas:** 100% Ar, 75% He/25% Ar

**Type of Current:** DCEP

### Approvals and Conformances:

- AWS A5.10, ER5183
- ASME SFA 5.10, ER5183
- AWS A5.01, Class S1, Schedule F
- CWB
- ABS
- CE
- VdTUV
- DB

## MaxalMig ER5356

### Benefits:

- high strength
- high ductility, fatigue strength and toughness
- very good color match after anodizing with 5XXX/6XXX base materials

### Typical Applications:

- applications using base metal 5086
- truck frames
- shipbuilding
- railcar
- bus panels

### Typical Weld Metal Chemistry:

Silicon .....	0.25
Iron .....	0.40
Copper .....	0.10
Manganese .....	0.05-0.20
Magnesium .....	4.5-5.5
Chromium .....	0.05-0.20
Zinc .....	0.10
Titanium .....	0.06-0.20
Beryllium .....	< 0.0003
Others Total .....	0.15
Aluminum.....	remainder

### Typical Mechanical Properties (AW):

Tensile Strength (psi)	38,000 (260 MPa)
Yield Strength (psi)	21,000 (145 MPa)
Elongation % in 2" (50mm)	13%

### Suggested GMAW welding procedures:

Diameter	Base Material		Wire Feed		
	Thickness	Amps	Volts	Speed	(ipm)
0.030"/0.8 mm	1/16" (1.6mm)	100	18	300	
	3/32" (2.4mm)	120	21	400	
	1/8" (3.2mm)	140	21	500	
	3/16"(4.8mm)	160	22	600	
0.035"/0.9mm	1/4" (6.4mm)	185	22	700	
	1/8" (3.2mm)	140	22	450	
	1/4" (6.4mm)	180	23	600	
0.047"/1.2mm	3/32" (2.4mm)	120	24	220	
	1/8" (3.2mm)	160	25	330	
	1/4" (6.4mm)	220	25	370	
	3/8" (9.5mm)	230	25	450	
0.062"/1.6mm	1/4" (6.4mm)	210	24	200	
	3/8" (9.5mm)	240	25	230	
	1/2" (12.7mm)	270	26	270	
	3/4" (19.1mm)	290	27	300	
1.00" (25.4mm)	310	28	320		

**Shielding Gas:** 100% Ar, 75% He/25% Ar

**Type of Current:** DCEP

### Approvals and Conformances:

- AWS A5.10, ER5356
- ASME SFA 5.10, ER5356
- AWS A5.01, Class S1, Schedule F
- CWB
- ABS
- VdTUV
- CE
- DB

# Aluminum Wires

## MaxalMig ER5554

### Benefits:

- moderate to high strength (33ksi/225 Mpa typical)
- developed for elevated temperature applications
- very good color match after anodizing with 5XXX/6XXX base materials
- excellent corrosion resistance

### Typical Applications:

- applications using 5454 base metal
- automotive
- heat exchangers

### Typical Weld Metal Chemistry:

Silicon.....	0.25
Iron.....	0.40
Copper.....	0.10
Manganese.....	0.50-1.0
Magnesium.....	2.4-3.0
Chromium.....	0.05-0.20
Zinc.....	0.25
Titanium.....	0.05-0.20
Beryllium.....	< 0.0003
Others Total.....	0.15
Aluminum.....	remainder

### Typical Mechanical Properties (AW):

Tensile Strength (psi)	33,000 (225 MPa)
Yield Strength (psi)	17,000 (115 MPa)
Elongation % in 2" (50mm)	15%

### Suggested GMAW welding procedures:

Diameter	Base Material		Wire Feed	
	Thickness	Amps	Volts	Speed (ipm)
0.030"/0.8 mm	1/16" (1.6mm)	100	18	300
	3/32" (2.4mm)	120	21	400
	1/8" (3.2mm)	140	21	500
	3/16" (4.8mm)	160	22	600
	1/4" (6.4mm)	185	22	700
0.035"/0.9mm	1/8" (3.2mm)	140	22	450
	1/4" (6.4mm)	180	23	600
0.047"/1.2mm	3/32" (2.4mm)	120	24	220
	1/8" (3.2mm)	160	25	330
	1/4" (6.4mm)	220	25	370
	3/8" (9.5mm)	230	25	450
0.062"/1.6mm	1/4" (6.4mm)	210	24	200
	3/8" (9.5mm)	240	25	230
	1/2" (12.7mm)	270	26	270
	3/4" (19.1mm)	290	27	300
	1.00" (25.4mm)	310	28	320

**Shielding Gas:** 100% Ar, 75% He/25% Ar

**Type of Current:** DCEP

### Approvals and Conformances:

- AWS A5.10, ER5554
- ASME SFA 5.10, ER5554
- AWS A5.01, Class S1, Schedule F
- CWB
- CE

## MaxalMig ER5556

### Benefits:

- very high strength
- high ductility, fatigue strength and toughness
- very good color match after anodizing with 5XXX/6XXX base materials
- excellent corrosion resistance when welded to 5456 base metal

### Typical Applications:

- applications using base metal with 42ksi (275 Mpa) minimum 5456
- pressure vessels

### Typical Weld Metal Chemistry:

Silicon.....	0.25
Iron.....	0.40
Copper.....	0.10
Manganese.....	0.50-1.0
Magnesium.....	4.7-5.5
Chromium.....	0.05-0.20
Zinc.....	0.25
Titanium.....	0.05-0.20
Beryllium.....	< 0.0003
Others Total.....	0.15
Aluminum.....	remainder

### Typical Mechanical Properties (AW):

Tensile Strength (psi)	43,000 (295 MPa)
Yield Strength (psi)	23,000 (155 MPa)
Elongation % in 2" (50mm)	12%

### Suggested GMAW welding procedures:

Diameter	Base Material		Wire Feed	
	Thickness	Amps	Volts	Speed (ipm)
0.030"/0.8 mm	1/16" (1.6mm)	100	18	300
	3/32" (2.4mm)	120	21	400
	1/8" (3.2mm)	140	21	500
	3/16" (4.8mm)	160	22	600
	1/4" (6.4mm)	185	22	700
0.035"/0.9mm	1/8" (3.2mm)	140	22	450
	1/4" (6.4mm)	180	23	600
0.047"/1.2mm	3/32" (2.4mm)	120	24	220
	1/8" (3.2mm)	160	25	330
	1/4" (6.4mm)	220	25	370
	3/8" (9.5mm)	230	25	450
0.062"/1.6mm	1/4" (6.4mm)	210	24	200
	3/8" (9.5mm)	240	25	230
	1/2" (12.7mm)	270	26	270
	3/4" (19.1mm)	290	27	300
	1.00" (25.4mm)	310	28	320

**Shielding Gas:** 100% Ar, 75% He/25% Ar

**Type of Current:** DCEP

### Approvals and Conformances:

- AWS A5.10, ER5556
- ASME SFA 5.10, ER5556
- AWS A5.01, Class S1, Schedule F
- CWB
- ABS
- CE

## MaxalTig R1100

### Benefits:

- highest ductility/formability
- higher electrical and thermal conductivity
- excellent corrosion resistance
- good hot cracking sensitivity in most applications

### Typical Applications:

- electrical conductors
- chemical storage tanks
- piping and tubing for chemicals
- refrigeration

### Typical Weld Metal Chemistry:

Silicon+Iron shall not exceed...	0.95
Copper.....	0.05-0.20
Manganese.....	0.05
Magnesium.....	—
Zinc.....	0.10
Titanium.....	—
Beryllium.....	< 0.0003
Others Total.....	0.15
Aluminum.....	99.0

### Typical Mechanical Properties (AW):

Tensile Strength (psi)	13,500 (90 MPa)
Yield Strength (psi)	—
Elongation % in 2" (50mm)	40%

### Suggested GTAW welding procedures:

Rod/Tungsten	Base Mat.	Gas Cup	Arc Travel
Diameter	Thickness	Diameter	Speed
1/16"(1.6mm)	.062"(1.6mm)	60-100	3/8"(9.5mm) 8-10 ipm
3/32"(2.4mm)	.094"(2.4mm)	85-115	3/8"(9.5mm) 10-12 ipm
.125"(3.2mm)	.1875"(4.8mm)	155-190	7/16"(0.4mm) 10-12 ipm
.156"(4.0mm)	.250"(6.4mm)	190-275	1/2"(12.7mm) 8-10 ipm
.187"(1.6mm)	.375"(9.5mm)	240-375	5/8"(15.9mm) 14-32 ipm

**Shielding Gas:** 100% Ar, 25% He/75% Ar

**Type of Current:** AC

### Approvals and Conformances:

- AWS A5.10, ER1100
- ASME SFA 5.10, ER1100
- AWS A5.01, Class S1, Schedule F
- CWB
- CE

## MaxalTig R4043

### Benefits:

- moderate strength (28ksi/190Mpa typical)
- low melting temperature and high fluidity
- minimizes hot cracking and distortion
- clean, bright welds

### Typical Applications:

- sport products - scooters/bicycles
- general repair and maintenance
- automotive/motorcycle frames and wheels
- welding 6XXX alloys

### Typical Weld Metal Chemistry:

Silicon .....	4.5-6.0
Iron .....	0.80
Copper .....	0.30
Manganese .....	0.05
Magnesium .....	0.05
Chromium .....	—
Zinc .....	0.10
Titanium .....	0.20
Beryllium .....	< 0.0003
Others Total .....	0.15
Aluminum.....	remainder

### Typical Mechanical Properties (AW):

Tensile Strength (psi)	28,000 (190 MPa)
Yield Strength (psi)	12,000 (80 MPa)
Elongation % in 2" (50mm)	24%

### Suggested GTAW welding procedures:

Rod/Tungsten Diameter	Base Mat. Thickness	Amps	Gas Cup Diameter	Arc Travel Speed
1/16"(1.6mm)	.062"(1.6mm)	60-100	3/8"(9.5mm)	8-10 ipm
3/32"(2.4mm)	.094" (2.4mm)	85-115	3/8"(9.5mm)	10-12 ipm
.125"(3.2mm)	.1875"(4.8mm)	155-190	7/16"(0.4mm)	10-12 ipm
.156"(4.0mm)	.250" (6.4mm)	190-275	1/2"(12.7mm)	8-10 ipm
.187"(1.6mm)	.375"(9.5mm)	240-375	5/8"(15.9mm)	14-32 ipm

**Shielding Gas:** 100% Ar, 25% He/75% Ar

**Type of Current:** AC

### Approvals and Conformances:

- AWS A5.10, ER4043
- ASME SFA 5.10, ER4043
- AWS A5.01, Class S1, Schedule F
- CWB
- CE

## MaxalTig R4047

### Benefits:

- low melting temperature and high fluidity
- excellent wetting action for joint sealing applications
- lowest shrinkage rate/reduced distortion
- minimizes hot cracking

### Typical Applications:

- welding 6XXX alloys
- radiator and air conditioning components
- general repair and maintenance
- water and gas tight applications

### Typical Weld Metal Chemistry:

Silicon .....	11.0-13.0
Iron .....	0.80
Copper .....	0.30
Manganese .....	0.15
Magnesium .....	—
Chromium .....	—
Zinc .....	0.10
Titanium .....	—
Beryllium .....	< 0.0003
Others Total .....	0.15
Aluminum.....	remainder

### Typical Mechanical Properties (AW):

Tensile Strength (psi)	38,000 (260 MPa)
Yield Strength (psi)	20,000 (135 MPa)
Elongation % in 2" (50mm)	11%

### Suggested GTAW welding procedures:

Rod/Tungsten Diameter	Base Mat. Thickness	Amps	Gas Cup Diameter	Arc Travel Speed
1/16"(1.6mm)	.062"(1.6mm)	60-100	3/8"(9.5mm)	8-10 ipm
3/32"(2.4mm)	.094" (2.4mm)	85-115	3/8"(9.5mm)	10-12 ipm
.125"(3.2mm)	.1875"(4.8mm)	155-190	7/16"(0.4mm)	10-12 ipm
.156"(4.0mm)	.250" (6.4mm)	190-275	1/2"(12.7mm)	8-10 ipm
.187"(1.6mm)	.375"(9.5mm)	240-375	5/8"(15.9mm)	14-32 ipm

**Shielding Gas:** 100% Ar, 25% He/75% Ar

**Type of Current:** AC

### Approvals and Conformances:

- AWS A5.10, ER4047
- ASME SFA 5.10, ER4047
- AWS A5.01, Class S1, Schedule F
- CE

## MaxalTig R4943

### Benefits:

- 25% higher UTS and 50% higher yield strength than 4043 in as-welded condition
- moderate to high strength (35ksi/240Mpa typical)
- low melting temperature and high fluidity
- heat treatable

### Typical Applications:

- current 4043 and 4643 applications, 1XXX, 3XXX, 5XXX with less than 3.0% Mg (example 5052), and 6XXX
- post weld aged, post weld heatreat & age applications
- automotive/motorcycle frames and wheels
- ladders and furniture

### Typical Weld Metal Chemistry:

Silicon .....	5.0-6.0
Iron .....	0.40
Copper .....	0.10
Manganese .....	0.05
Magnesium .....	0.30-0.50
Chromium .....	—
Zinc .....	0.10
Titanium .....	0.15
Beryllium .....	< 0.0003
Others Total .....	0.15
Aluminum.....	remainder

### Typical Mechanical Properties (AW):

Tensile Strength (psi)	35,000 (240 MPa)
Yield Strength (psi)	18,000 (125 MPa)
Elongation % in 2" (50mm)	16%

### Suggested GTAW welding procedures:

Rod/Tungsten Diameter	Base Mat. Thickness	Amps	Gas Cup Diameter	Arc Travel Speed
1/16"(1.6mm)	.062"(1.6mm)	60-100	3/8"(9.5mm)	8-10 ipm
3/32"(2.4mm)	.094" (2.4mm)	85-115	3/8"(9.5mm)	10-12 ipm
.125"(3.2mm)	.1875"(4.8mm)	155-190	7/16"(0.4mm)	10-12 ipm
.156"(4.0mm)	.250" (6.4mm)	190-275	1/2"(12.7mm)	8-10 ipm
.187"(1.6mm)	.375"(9.5mm)	240-375	5/8"(15.9mm)	14-32 ipm

**Shielding Gas:** 100% Ar, 25% He/75% Ar

**Type of Current:** AC

### Approvals and Conformances:

- AWS A5.10, ER4943
- ASME SFA 5.10, ER4943
- AWS A5.01, Class S1, Schedule F
- CWB
- ABS
- CE

# Aluminum Wires

## MaxalTig R5183

### Benefits:

- very high strength
- high ductility, fatigue strength and toughness
- very good color match after anodizing with 5XXX/6XXX base materials
- excellent corrosion resistance when welded to 5083 base metal

### Typical Applications:

- applications using base metal with 40ksi (275 Mpa) minimum (5083)
- shipbuilding
- pressure vessels
- cryogenic tanks

### Typical Weld Metal Chemistry:

Silicon	0.40
Iron	0.40
Copper	0.10
Manganese	0.50-1.0
Magnesium	4.3-5.2
Chromium	0.05-0.25
Zinc	0.25
Titanium	0.15
Beryllium	< 0.0003
Others Total	0.15
Aluminum	remainder

### Typical Mechanical Properties (AW):

Tensile Strength (psi)	41,000 (280 MPa)
Yield Strength (psi)	22,000 (150 MPa)
Elongation % in 2" (50mm)	12%

### Suggested GTAW welding procedures:

Rod/Tungsten		Base Mat.		Gas Cup		Arc Travel	
Diameter	Thickness	Amps	Diameter	Speed			
1/16"(1.6mm)	.062"(1.6mm)	60-100	3/8"(9.5mm)	8-10 ipm			
3/32"(2.4mm)	.094"(2.4mm)	85-115	3/8"(9.5mm)	10-12 ipm			
.125"(3.2mm)	.1875"(4.8mm)	155-190	7/16"(0.4mm)	10-12 ipm			
.156"(4.0mm)	.250"(6.4mm)	190-275	1/2"(12.7mm)	8-10 ipm			
.187"(1.6mm)	.375"(9.5mm)	240-375	5/8"(15.9mm)	14-32 ipm			

**Shielding Gas:** 100% Ar, 25% He/75% Ar

**Type of Current:** AC

### Approvals and Conformances:

- AWS A5.10, R5183
- ASME SFA 5.10, R5183
- AWS A5.01, Class S1, Schedule F
- CWB
- ABS
- CE

## MaxalTig R5356

### Benefits:

- high strength
- high ductility, fatigue strength and toughness
- very good color match after anodizing with 5XXX/6XXX base materials

### Typical Applications:

- applications using base metal 5086
- truck frames
- shipbuilding
- railcar
- bus panels

### Typical Weld Metal Chemistry:

Silicon	0.25
Iron	0.40
Copper	0.10
Manganese	0.05-0.20
Magnesium	4.5-5.5
Chromium	0.05-0.20
Zinc	0.10
Titanium	0.06-0.20
Beryllium	< 0.0003
Others Total	0.15
Aluminum	remainder

### Typical Mechanical Properties (AW):

Tensile Strength (psi)	38,000 (260 MPa)
Yield Strength (psi)	21,000 (145 MPa)
Elongation % in 2" (50mm)	13%

### Suggested GTAW welding procedures:

Rod/Tungsten		Base Mat.		Gas Cup		Arc Travel	
Diameter	Thickness	Amps	Diameter	Speed			
1/16"(1.6mm)	.062"(1.6mm)	60-100	3/8"(9.5mm)	8-10 ipm			
3/32"(2.4mm)	.094"(2.4mm)	85-115	3/8"(9.5mm)	10-12 ipm			
.125"(3.2mm)	.1875"(4.8mm)	155-190	7/16"(0.4mm)	10-12 ipm			
.156"(4.0mm)	.250"(6.4mm)	190-275	1/2"(12.7mm)	8-10 ipm			
.187"(1.6mm)	.375"(9.5mm)	240-375	5/8"(15.9mm)	14-32 ipm			

**Shielding Gas:** 100% Ar, 25% He/75% Ar

**Type of Current:** AC

### Approvals and Conformances:

- AWS A5.10, R5356
- ASME SFA 5.10, R5356
- AWS A5.01, Class S1, Schedule F
- CWB
- ABS
- CE

## MaxalTig R5554

### Benefits:

- moderate to high strength (33ksi/225 Mpa typical)
- developed for elevated temperature applications
- very good color match after anodizing with 5XXX/6XXX base materials
- excellent corrosion resistance

### Typical Applications:

- applications using 5454 base metal
- automotive
- heat exchangers

### Typical Weld Metal Chemistry:

Silicon	0.25
Iron	0.40
Copper	0.10
Manganese	0.50-1.0
Magnesium	2.4-3.0
Chromium	0.05-0.20
Zinc	0.25
Titanium	0.05-0.20
Beryllium	< 0.0003
Others Total	0.15
Aluminum	remainder

### Typical Mechanical Properties (AW):

Tensile Strength (psi)	33,000 (225 MPa)
Yield Strength (psi)	17,000 (115 MPa)
Elongation % in 2" (50mm)	15%

### Suggested GTAW welding procedures:

Rod/Tungsten		Base Mat.		Gas Cup		Arc Travel	
Diameter	Thickness	Amps	Diameter	Speed			
1/16"(1.6mm)	.062"(1.6mm)	60-100	3/8"(9.5mm)	8-10 ipm			
3/32"(2.4mm)	.094"(2.4mm)	85-115	3/8"(9.5mm)	10-12 ipm			
.125"(3.2mm)	.1875"(4.8mm)	155-190	7/16"(0.4mm)	10-12 ipm			
.156"(4.0mm)	.250"(6.4mm)	190-275	1/2"(12.7mm)	8-10 ipm			
.187"(1.6mm)	.375"(9.5mm)	240-375	5/8"(15.9mm)	14-32 ipm			

**Shielding Gas:** 100% Ar, 25% He/75% Ar

**Type of Current:** AC

### Approvals and Conformances:

- AWS A5.10, ER5554
- ASME SFA 5.10, ER5554
- AWS A5.01, Class S1, Schedule F
- CWB
- CE

## MaxalTig R5556

### Benefits:

- very high strength
- high ductility, fatigue strength and toughness
- very good color match after anodizing with 5XXX/6XXX base materials
- excellent corrosion resistance when welded to 5456 base metal

### Typical Applications:

- applications using base metal with 42ksi (275 MPa) minimum 5456
- pressure vessels

### Typical Weld Metal Chemistry:

Silicon.....	0.25
Iron.....	0.40
Copper.....	0.10
Manganese.....	0.50-1.0
Magnesium.....	4.7-5.5
Chromium.....	0.05-0.20
Zinc.....	0.25
Titanium.....	0.05-0.20
Beryllium.....	< 0.0003
Others Total.....	0.15
Aluminum.....	remainder

### Typical Mechanical Properties (AW):

Tensile Strength (psi)	43,000 (295 MPa)
Yield Strength (psi)	23,000 (155 MPa)
Elongation % in 2" (50mm)	12%

### Suggested GTAW welding procedures:

Rod/Tungsten Diameter	Base Mat. Thickness	Gas	Cup Diameter	Arc	Travel Speed
1/16" (1.6mm)	.062" (1.6mm)	60-100	3/8" (9.5mm)	8-10 ipm	
3/32" (2.4mm)	.094" (2.4mm)	85-115	3/8" (9.5mm)	10-12 ipm	
.125" (3.2mm)	.1875" (4.8mm)	155-190	7/16" (11.1mm)	10-12 ipm	
.156" (4.0mm)	.250" (6.4mm)	190-275	1/2" (12.7mm)	8-10 ipm	
.187" (4.7mm)	.375" (9.5mm)	240-375	5/8" (15.9mm)	14-32 ipm	

**Shielding Gas:** 100% Ar, 25% He/75% Ar

**Type of Current:** AC

### Approvals and Conformances:

- AWS A5.10, R5556
- ASME SFA 5.10, R5556
- AWS A5.01, Class S1, Schedule F
- CWB
- ABS
- CE

### Maxal PAC Drum

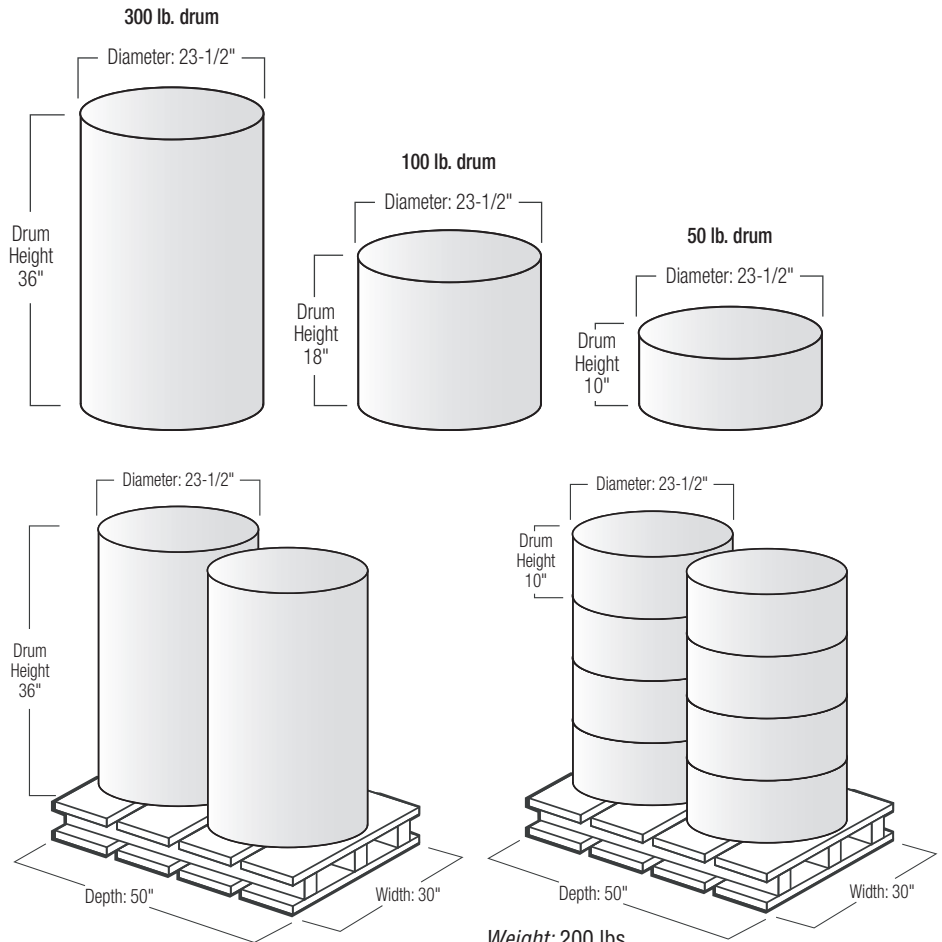

**Weight: 600 lbs.**  
**Master pallet dimensions: 30" x 50"**

**Weight: 200 lbs.**  
**Master pallet dimensions: 30" x 50"**

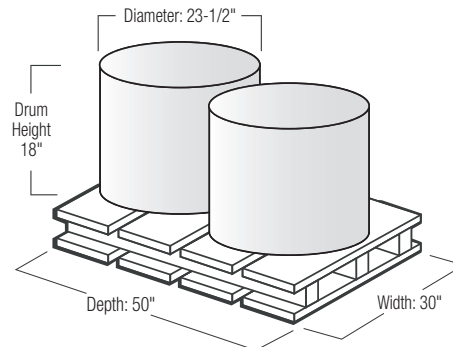

**Weight: 200 lbs.**  
**Master pallet dimensions: 30" x 50"**